

TORROT 

Owner's Manual
Maintenance+Warranty

MUVI



Welcome to Torrot

Thank you for acquiring our MUVI electric scooter! We are pleased to welcome you to the family of Torrot Electric product users.

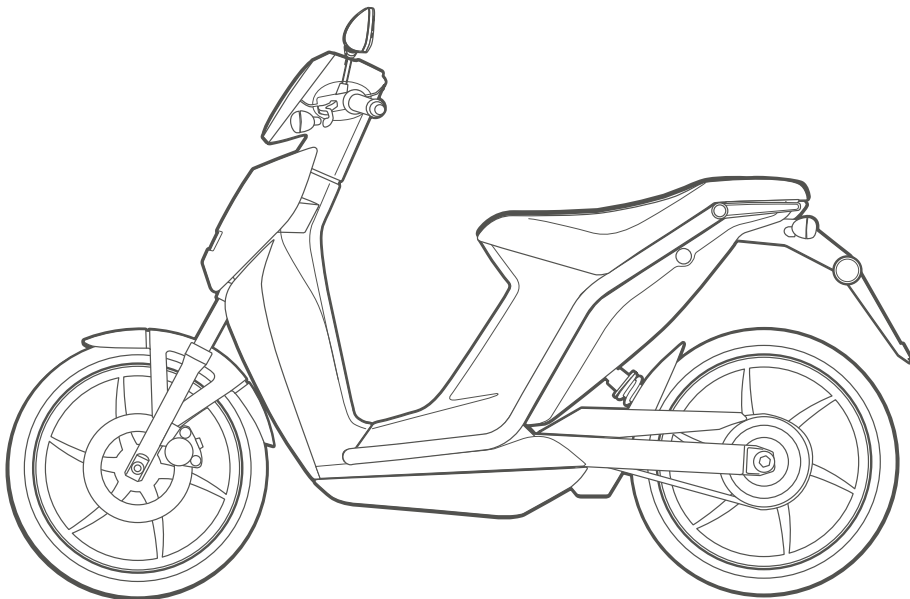

This manual contains information regarding the correct use and maintenance of your MUVI. For your security and comfort, we recommend you read these instructions carefully.

ISO 9001 - ISO 14001

BUREAU VERITAS
Certification



PERSONAL MOBILITY
INTERCONNECTED

Legend
 **series**

Owner's Manual

Table of contents

INTRODUCTION	06	TURN-ON SEQUENCE	28
PRE-OPERATION CHECKS	07	REMOVING THE BATTERIES	29
CLOTHING	07	INSERTING THE BATTERIES	29
RIDING SAFELY	07	CHARGING THE BATTERIES	30
CHARACTERISTICS	08	BATTERY PRECAUTIONS	31
COMPONENTS	09	MAINTENANCE	32
CONTROLS	10	BELT TENSION	32
DASHBOARD	12	TYRE PRESSURE	33
EXTRA DISPLAYS AVAILABLE	13	BRAKE FLUID	34
DASHBOARD WARNING LIGHTS AND SYMBOLS	14	BRAKE CALLIPERS	34
RIDING MODES	16	ACCESSING THE HEADLIGHT	35
IGNITION SWITCH	17	CHANGING THE LIGHT BULB	36
START SCREENS	19	ADJUSTING THE HEADLIGHT	37
SET BUTTON	21	CLEANING	38
SETTING THE TIME	21	STICKER LOCATIONS	39
BLUETOOTH APP	22	VIN NUMBER	40
STORAGE COMPARTMENT	25	WARRANTY TERMS AND CONDITIONS	41
USING THE CENTRE STAND	26		
USAGE AND PRECAUTIONS	27		

INTRODUCTION



The first lightweight electric scooter designed to move you from here to there in a breeze: it's easy to ride and very comfortable. It comes with a small space under the seat for a jet helmet, front and rear LED daytime running lights, disc brakes and everything else you need to get around town safely, enjoyably and efficiently. It's extrovert, laid-back design has been created for people like you, who value time and practicality above all else.

PRE-OPERATION CHECKS

Before riding, check that:

- The charger is disconnected
- The battery has sufficient charge
- The lights and horn work properly, check the headlight, blinkers and brake light.
- The brakes work properly
- The tyres have the correct pressure
- The rear-view mirrors are correctly positioned
- The belt has the correct tension.

CLOTHING

Riding motorcycles has its risks, and prevention is better than cure, so it's best to be protected:

- Always fasten the helmet
- Wear comfortable, snug-fitting clothes. Loose-fitting clothes can complicate manoeuvres and become tangled in the motorbike's parts.
- Wear comfortable, snug-fitting footwear so they don't fall off while riding. Avoid heels that are too high or thongs.

RIDING SAFELY

- Always carry your driving licence and a valid insurance policy
- Always grasp the handlebar with both hands
- Always remain seated, do not stand.
- Always obey traffic signs and police officers
- Do not let an inexperienced person ride your motorbike.

CHARACTERISTICS

MUVI SPECIFICATIONS

CHASSIS	TUBULAR STEEL
FRONT SUSPENSION	HYDRAULIC TELESCOPIC FORK
REAR SUSPENSION	SIDE MONOSHOCK WITH PRELOAD ADJUSTMENT
BRAKES	HYDRAULIC COMBINED BRAKING SYSTEM 220mm FRONT - 200mm REAR
TRANSMISSION	HTD 1:5 TOOTHED BELT
MOTOR	TORROT BRUSHLESS AC PMSM
POWER / TORQUE	(L3e-A1 = 3kw / L1e-B = 2.65kw) / 35Nm
MAXIMUM SPEED	L3e 70 km/h / L1e 45 km/h
BATTERY	REMOVABLE 2 x 48V 35.2Ah LiNiCoMn / RANGE UP TO 110km *
DIAGNOSTICS - CONNECTIVITY	ECU (Electronic Control Unit) CAN-BUS / BLUETOOTH
DASHBOARD	INTELLIGENT, 320x240 4" LCD CUSTOMISABLE VIA APP (iOS/Android)
RIMS	ALUMINIUM 16"x2.15
TYRES	90/80-R16
WEIGHT	96KG (WITH BATTERIES)
MAXIMUM WEIGHT	275kg
CHARGER	54.6V 5A DUAL CHARGER (7 HOURS)
OPTIONAL	54.6V 10A DUAL CHARGER (4 HOURS) HIGH WINDSCREEN LOW WINDSCREEN LUGGAGE RACK TOP CASE 29L TOP CASE 40L

* L3e-A1 approved up to 85km in accordance with WMTC-2
L1e-B approved up to 93km in accordance with CEPE R47
L1e-25 approved up to 110km in accordance with CEPE R47

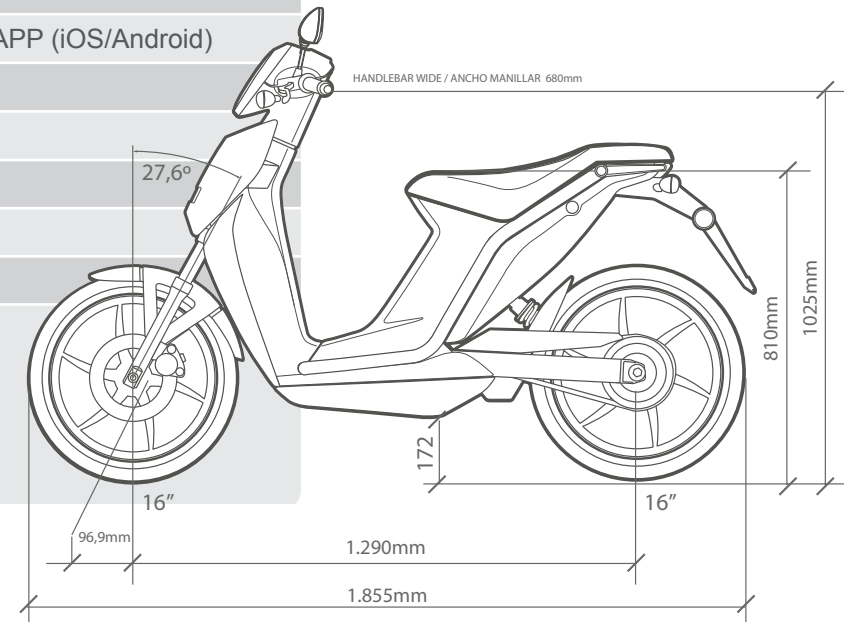

COMPONENTS

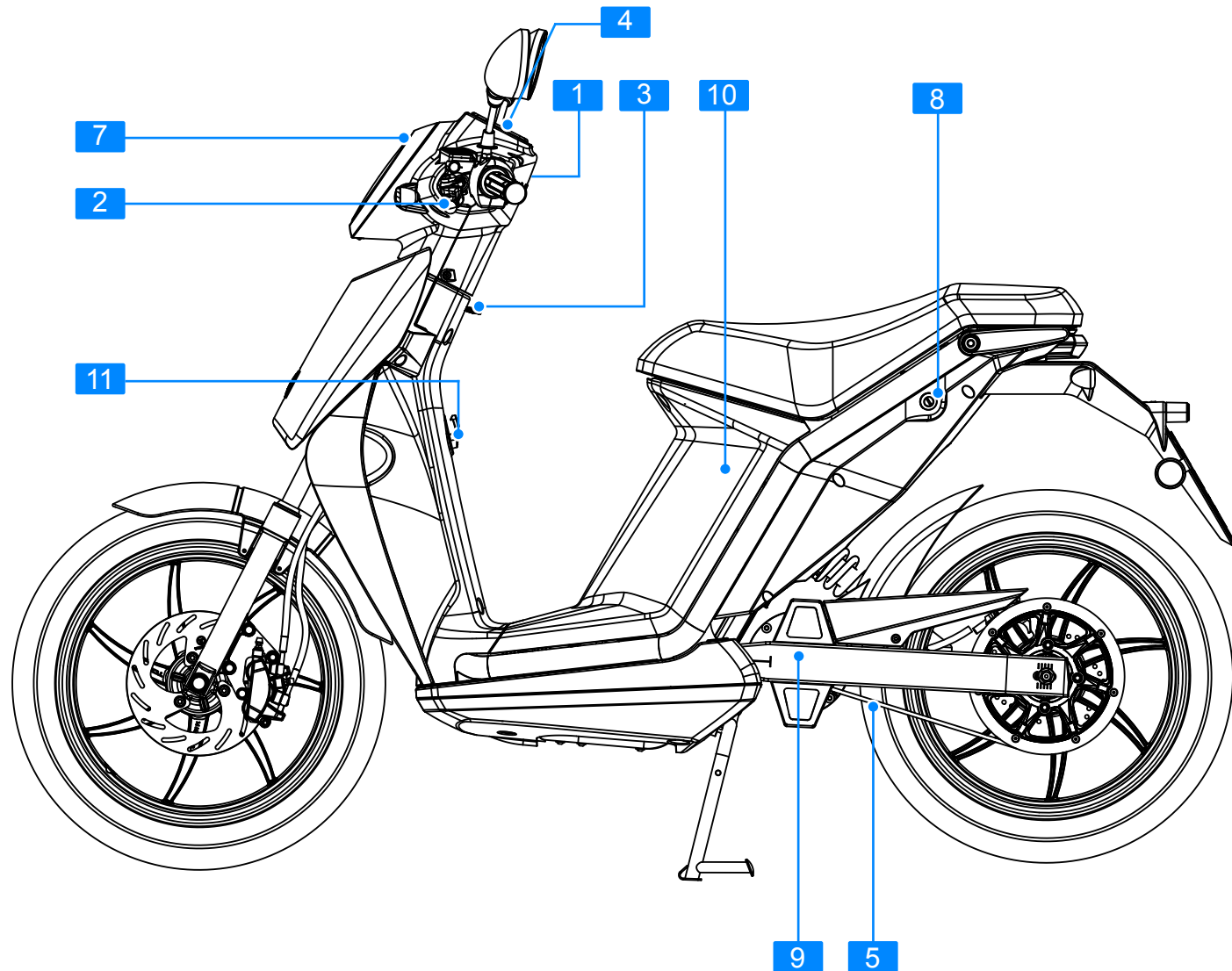

- 1 ACCELERATOR
- 2 BRAKES
- 3 IGNITION SWITCH
- 4 DASHBOARD
- 5 BELT
- 6 CENTRE STAND
- 7 HEADLIGHT
- 8 LOCK
- 9 MOTOR
- 10 BATTERY
- 11 LUGGAGE HOOK

Owner's Manual
CONTROLS

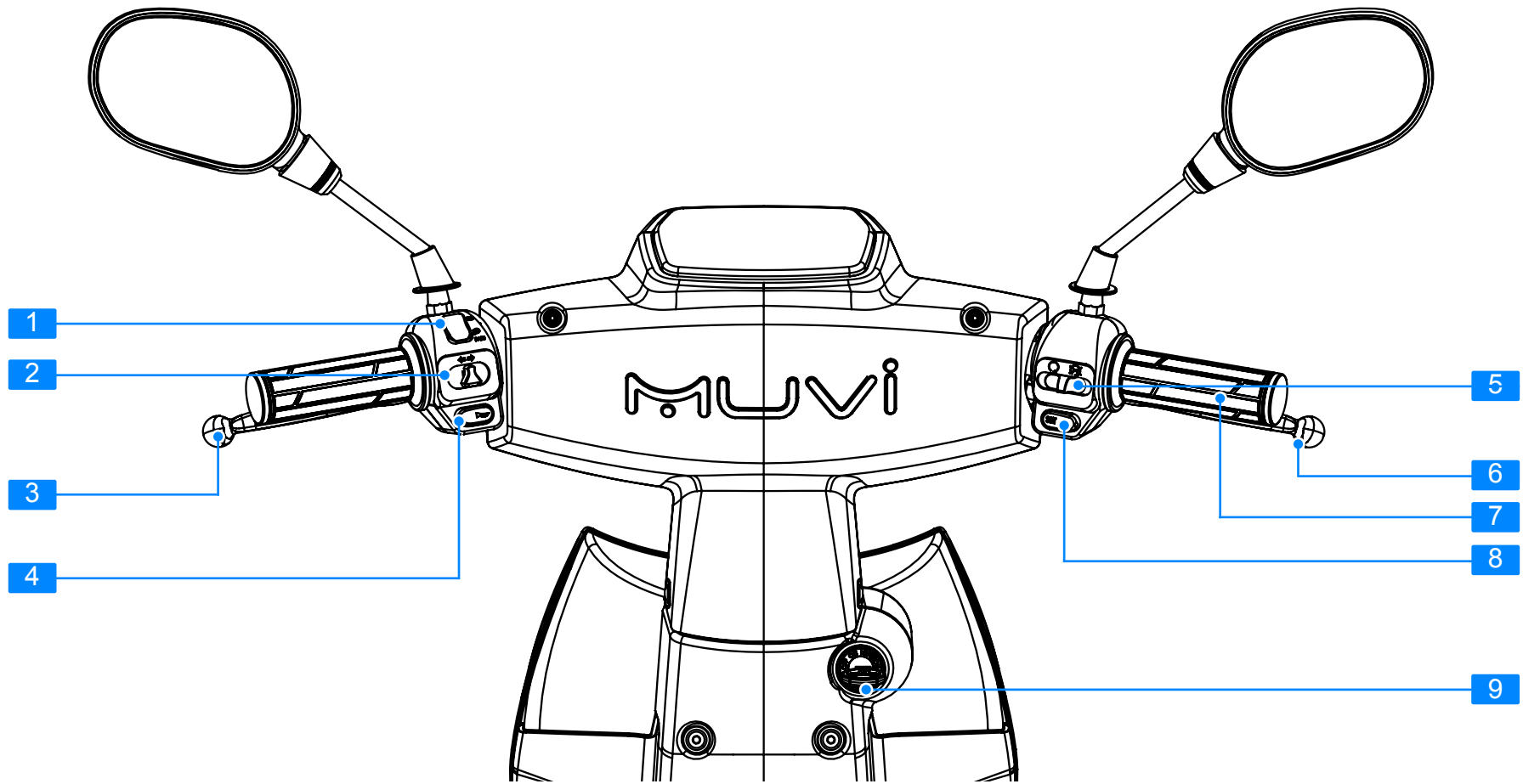

CONTROLS

1. HIGH AND LOW BEAM

This button lets you switch between high and low beam. You can flash the high beam by pressing the part closest to you.

2. BLINKERS

To signal your intentions on the road you should always use the blinkers before turning. This warns other drivers of your manoeuvre. Move the lever to the left to activate the left blinkers and to the right to activate the right ones. Press the button to deactivate the blinkers.

3. REAR BRAKE - COMBINED BRAKE SYSTEM

To brake using the CBS system, squeeze this lever. This system balance the brake force between rear wheel (main pressure) and the front wheel (light braking force).

4. HORN

Press this button to sound the horn. It emits a high tone.

5. DISCONNECTION BUTTON

Move the button to the right to put the motorbike into STOP mode. The motorbike will remain on.

6. FRONT BRAKE

This lever brakes only on the front wheel.

Braking with this brake give a effective and reactive braking force. But if you squeeze the lever forcefully in an abrupt manner the wheel will lock and the motorbike will lose stability. Always squeeze the brake levers gently.

7. ACCELERATOR

Move your wrist downward to rotate the grip and send power to the motor. To keep all components in good condition avoid applying maximum acceleration in an abrupt manner.

8. SET BUTTON

For more information on the SET button read the corresponding page (page 21).

9. IGNITION SWITCH

For more information on the ignition switch read the

DASHBOARD

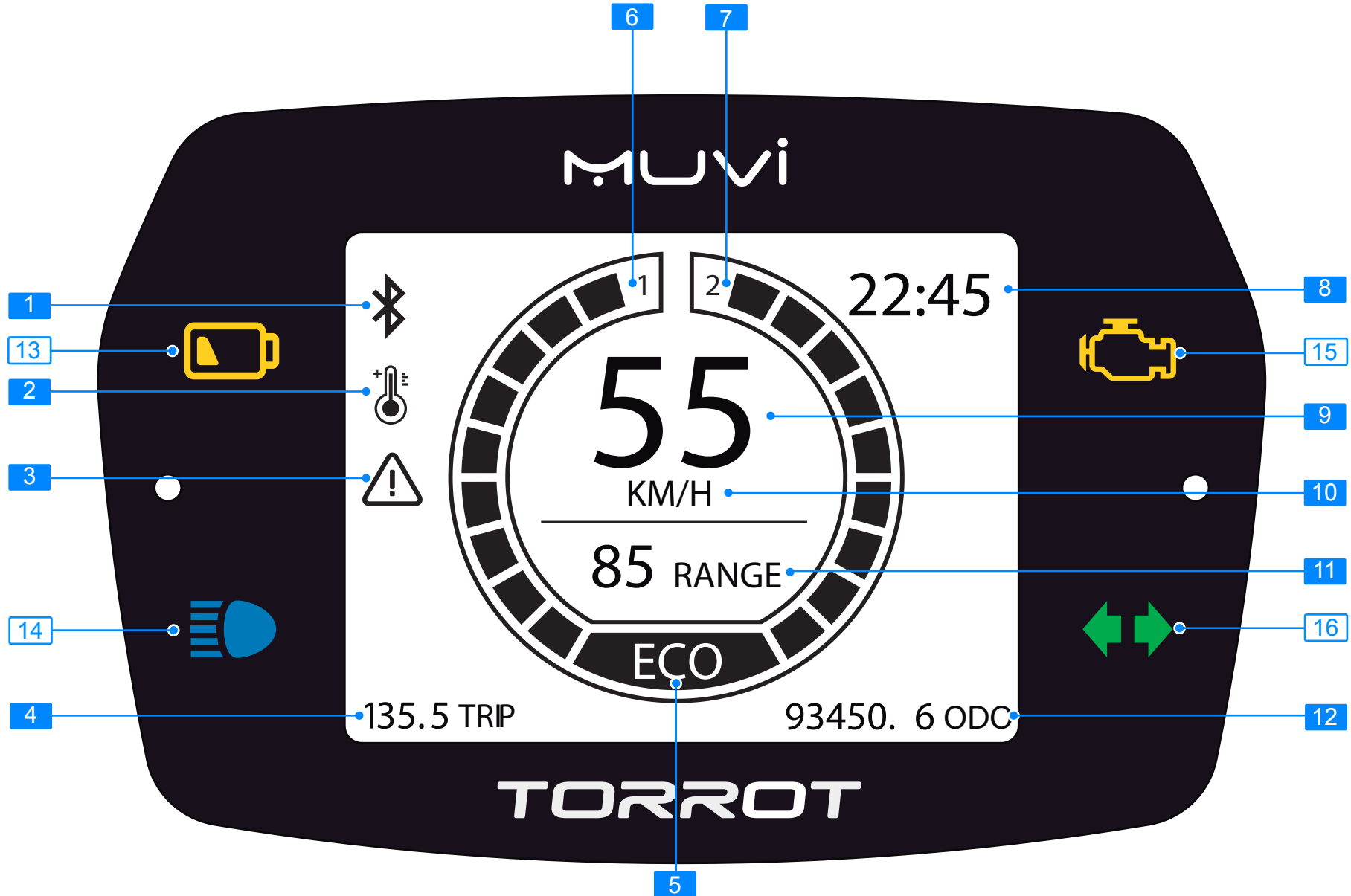

EXTRA DISPLAYS AVAILABLE

You can change the display type via the MUVI application.

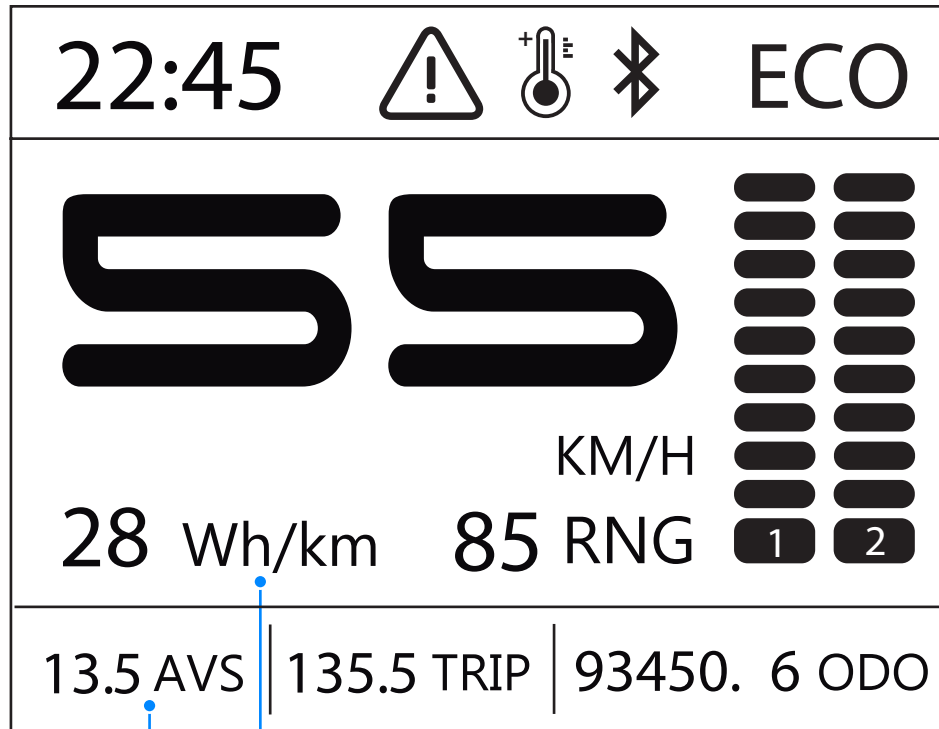

18

19

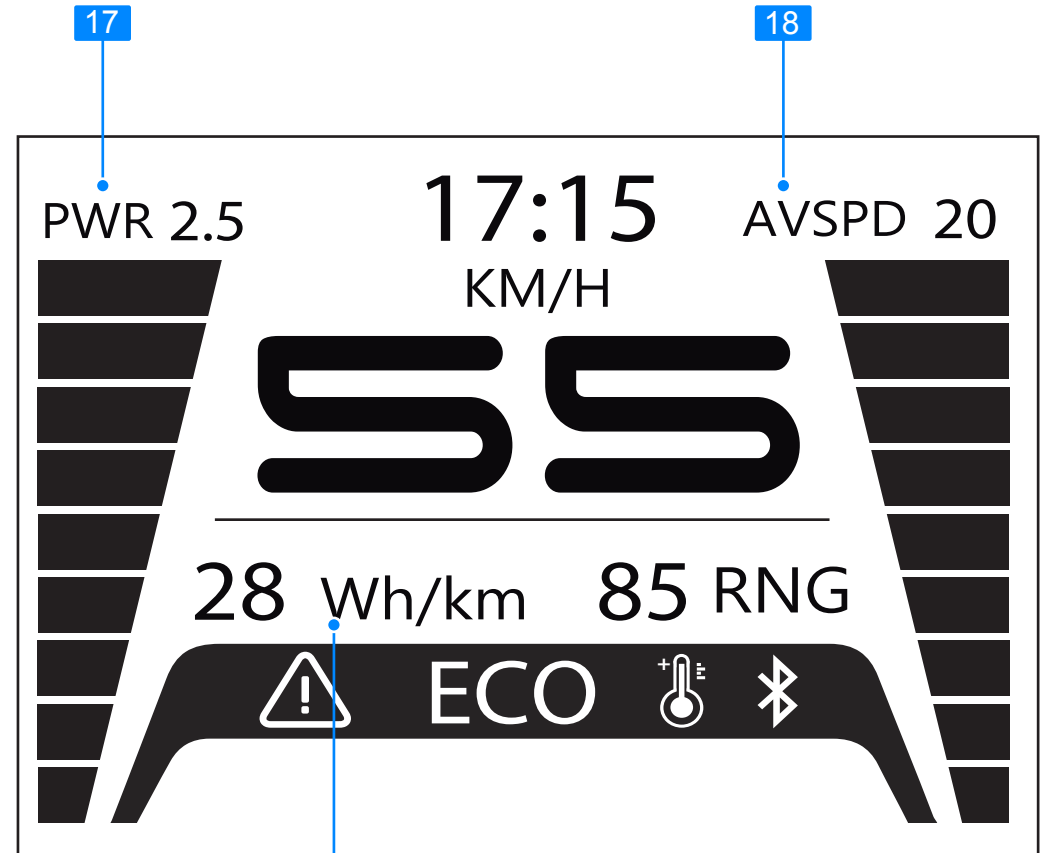

19

DASHBOARD WARNING LIGHTS AND SYMBOLS



1. BLUETOOTH INDICATOR

This indicator shows if there are any Bluetooth devices connected to the motorbike.

2. TEMPERATURE INDICATOR

Indicates a problem, the temperature is either too high or too low.



HIGH TEMPERATURE

This symbol means that a component has reached a high temperature, resulting in reduced torque and power until the temperature stabilises.



LOW TEMPERATURE

This symbol means the internal battery-pack temperature is below -5°C . Remove the batteries and bring them indoors so they can warm up a little.



3. WARNING

Except for OBD errors, this icon will light up when an error is detected.

4. TRIP

Shows the kilometres travelled since the last time it was reset.

5. RIDING MODE

Shows the mode in which the motorbike is being ridden. There are two modes: ECO and FULL. If while in ECO mode two arrows appear beside ECO, this indicates that FULL mode can be engaged.

6. BATTERY 1

Shows the charge level of battery 1

7. BATTERY 2

Shows the charge level of battery 2

8. TIME

Shows the time

9. SPEED

Shows the travel speed

10. UNITS OF SPEED

Indicates the unit of speed being used. Km/h or MPH.

DASHBOARD WARNING LIGHTS AND SYMBOLS

11. RANGE

Shows how many kilometres or miles (depending on configuration) can be travelled before running out of battery.

Depending of the type of battery, the aging of it and the style of riding, the range showed on the dashboar may vary.

This is a dynamic value which will vary with time and vehicle use. To calculate the range more accurately, the motorbike takes riding style and usual consumption into account.

12. ODOMETER

Shows the total amount of kilometres or miles travelled by the motorbike (depending on configuration).



13. LOW BATTERY WARNING LIGHT

This light turns on when one of the batteries is below 20%.



14. HIGH BEAM INDICATOR

This light indicates that high beam is on.



15. OBD FAULT WARNING LIGHT

When this light turns on it means the OBD has detected a fault. Executing the diagnostics via the application will tell you more about this fault.



16. BLINKER INDICATOR

When you activate the blinkers this light will blink.

17. POWER

Shows the motorbike's instantaneous power.

18. AVSPD / AVS

Shows the average speed at which the MUVI has been ridden.

19. UNITS OF CONSUMPTION

Shows the average consumption per unit of distance (kilometres or miles depending on which you have set).

RIDING MODES

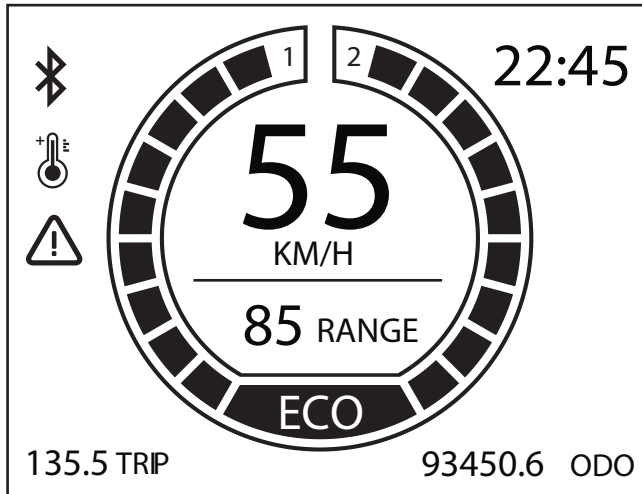

ECO

The motorbike starts in this mode by default. This mode is characterised by smooth power delivery, providing maximum reduction of consumption. This allows for a greater range.

This mode is also activated when the motorbike starts with only one battery, when the batteries are unbalanced over 20% and when at least one of the batteries are under 20% of charge.

While riding in ECO mode, you can engage FULL mode when two arrows appear beside ECO.

*It is inadvisable to carry a passenger in this mode

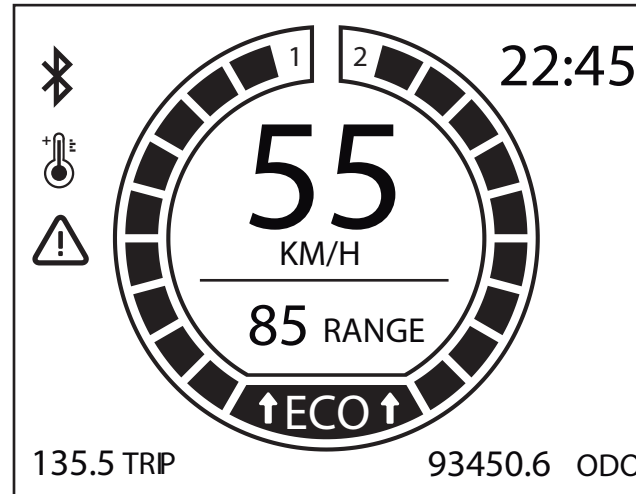

FULL

This mode delivers maximum performance and power, which will effect the range.

This riding mode is only available when both batteries are connected and the difference in charge level between them is less than 20%.

When one of the batteries has a lower level than 20%, the low battery warning turns on and ECO mode is activated automatically.

While riding in FULL mode, ECO mode can be engaged when desired.

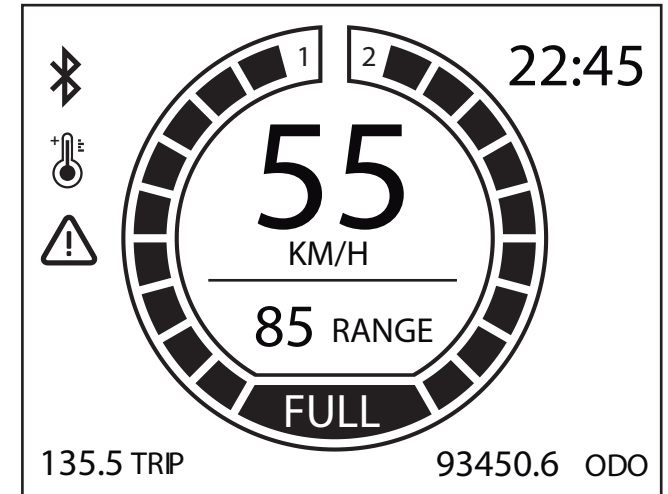

IGNITION SWITCH



1. OFF

In this position the motorbike is off, however, the steering is unlocked.

2. ON

In this position the motorbike is on and ready to go, provided it is off its centre stand.

3. LOCK

In this position the motorbike is off and the steering can be locked toward one side or the other. To engage this position, press the key inward then turn.

START SCREENS

The display will turn on when the key is in the ON position. Depending on whether or not there are initial errors, either of the following images will be displayed. Read each message description to understand its meaning.

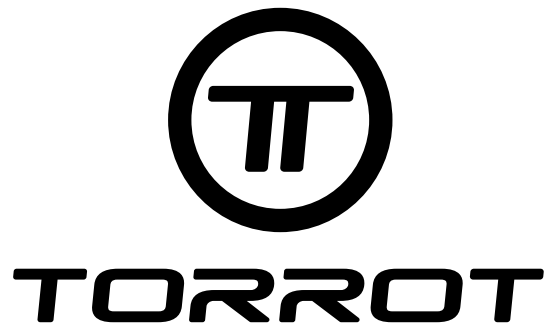

The display will show the Torrot logo upon starting the motorbike.

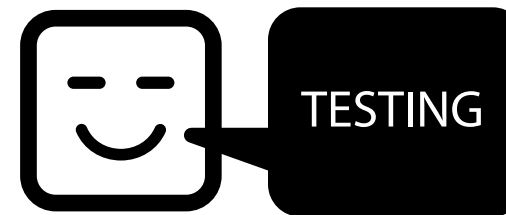

It will then test that all the components are in working order.

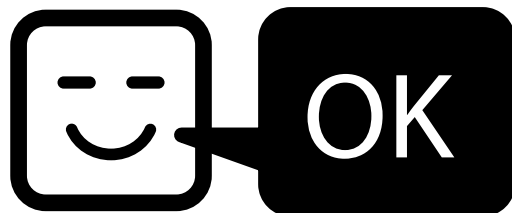

If all is fine this image will be shown, meaning you can start riding.



This image means that it's time to take the MUVI for its routine service.

START SCREENS

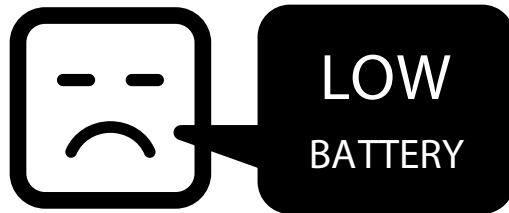

One of the motorbike's batteries is below 20% of its capacity.

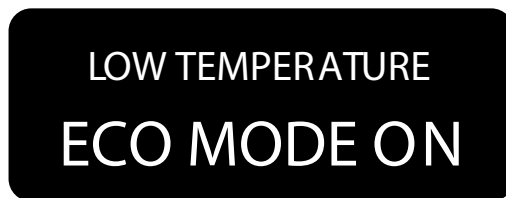

The temperature of a component is too low. ECO mode will be engaged.



The temperature of one or more components is too high and ECO mode will be engaged.



Two incompatible batteries have been connected. The motorbike will not work.

START SCREENS



**BATTERY ERROR
ECO MODE ON**

There is an error in one of the batteries. ECO mode will be engaged.



**BATTERY NOT DETECTED
SINGLE BATTERY
MODE**

Only one battery has been detected. ECO mode will be engaged.



**BATTERIES UNBALANCED
ECO MODE ON**

The batteries have unequal charges. ECO mode will be engaged.



UNABLE TO RUN
Please check MUVI APP

The motorbike is unable to run. Check the errors via the application and contact the technical service centre.

SET BUTTON

The SET button performs three functions:

- **When it is possible, it switches the riding mode:**

The riding modes, as well as when it is possible to switch between them, have been explained on the previous page. To do this, press the SET button for 1 second. The dashboard will indicate that the mode has changed.

- **Resets the kilometres shown on the TRIP meter:**

Press the SET button for 3 seconds to reset the kilometres shown on the TRIP meter.

- **Changes from km/h to mph:**

To change from the Metric (km/h) to the Imperial system (mph) simultaneously press the SET button and apply the right brake for 3 to 5 seconds.

SETTING THE TIME

To set the time the motorcycle must be connected to a smartphone via Bluetooth. The time will be synchronised as explained below.

BLUETOOTH APP

An application has been developed to connect your smartphone to the MUVI.* There is a sticker inside the helmet compartment which has the motorbike's identifier and the PIN number you must enter to establish a connection.

1 The start screen for the MUVI Bluetooth application. If you've already signed up then log in with your account. If you still don't have an account then what are you waiting for? Press "Sign up for Torrot".

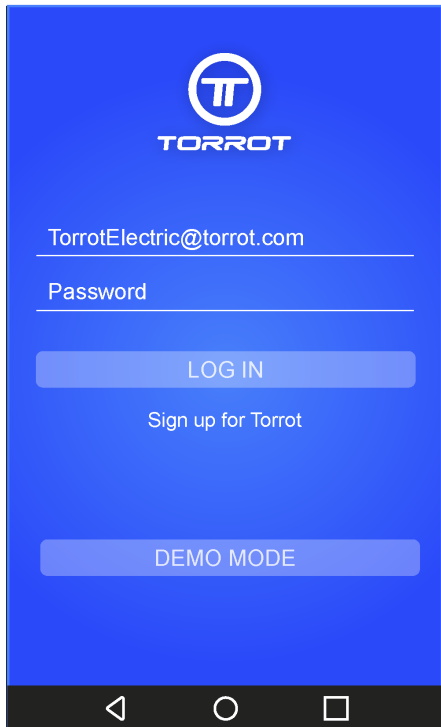

2 Enter your information and sign up. You will be taken back to screen 1. Enter your account and password and advance to the next page. You're ever closer to enjoying the Torrot interconnected mobility experience.

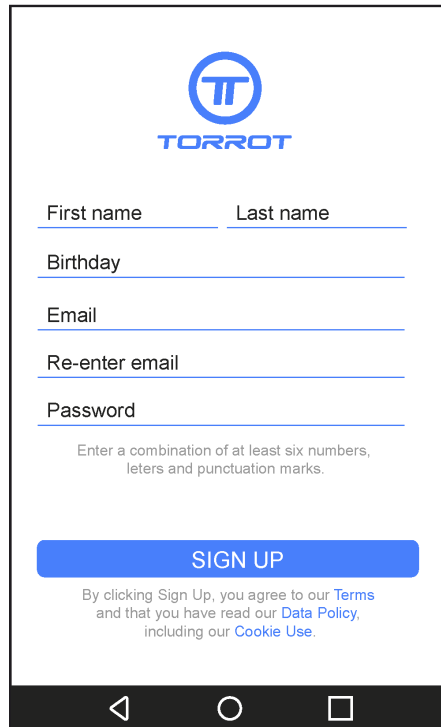

3 Bluetooth application menu. Press "Support" to access the menu for connecting your motorbike and smartphone.

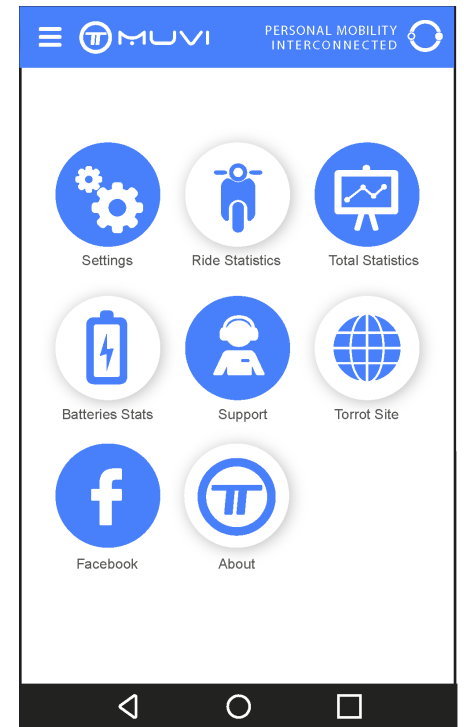

*The smartphone's Bluetooth must be the low energy version (BTLE) to be compatible.

BLUETOOTH APP

4 This is the technical support screen where you can access the website, send an email, send your motorcycle logs to support if there is an error, view errors recorded by the OBD and scan for devices to connect with your MUVI.

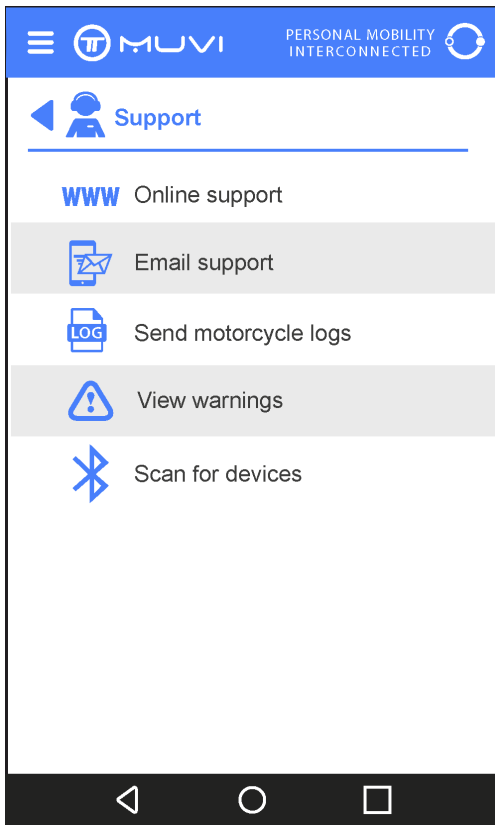

5 If the OBD finds an error and it is shown on the display as explained in the symbols section. You can access this screen to see the error and convey it to us if necessary.

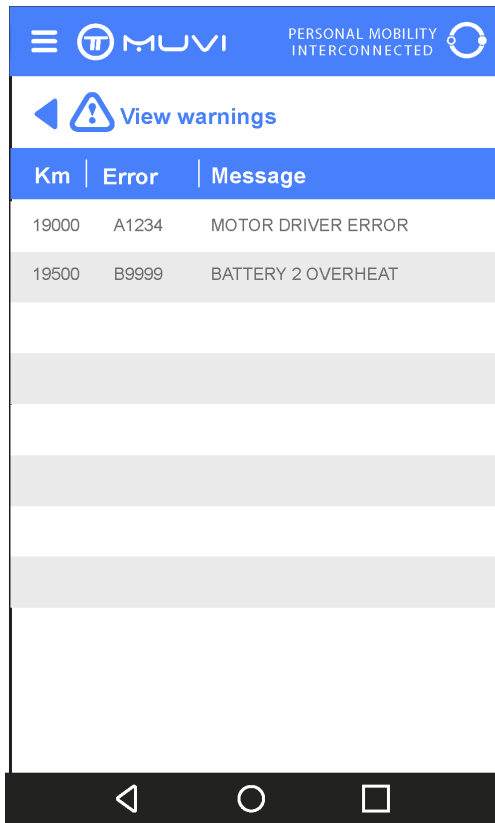

BLUETOOTH APP

6 You can access "Settings" from screen number 3. This menu lets you set the units, synchronise the smartphone time with that of the display, reset the TRIP meter and select different dashboard layouts.

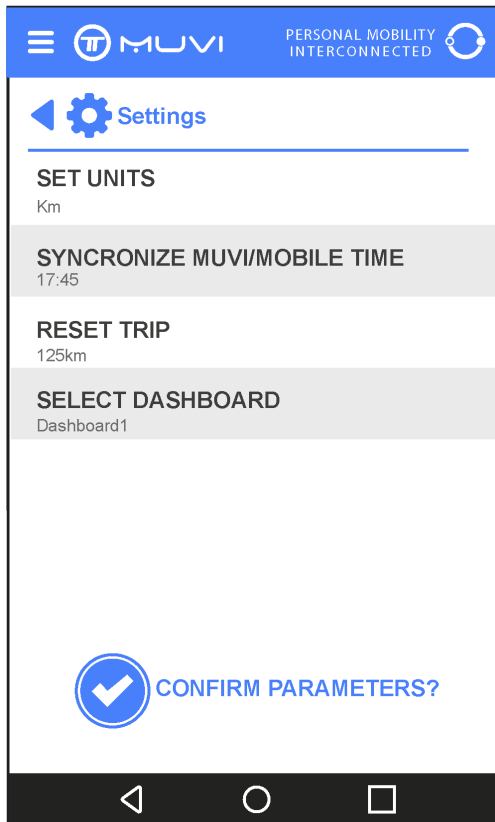

7 If you want to see a summary of what you've done with the MUVI, access "Ride Statistics" from the menu and amuse yourself viewing the amount of time you've ridden, maximum speed reached and average consumption.

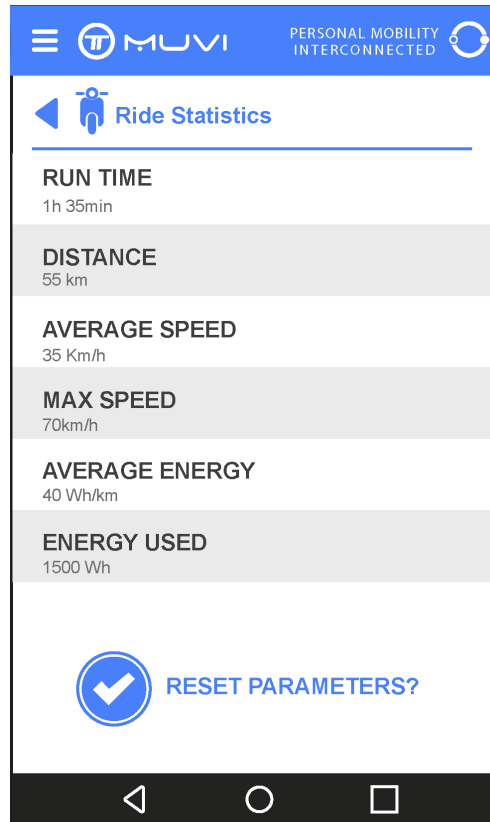

8 To access the status of the batteries press "Batteries Stats". Information about the health of your batteries, their remaining capacity and energy, charge and discharge cycles and the days without charging is all displayed here.

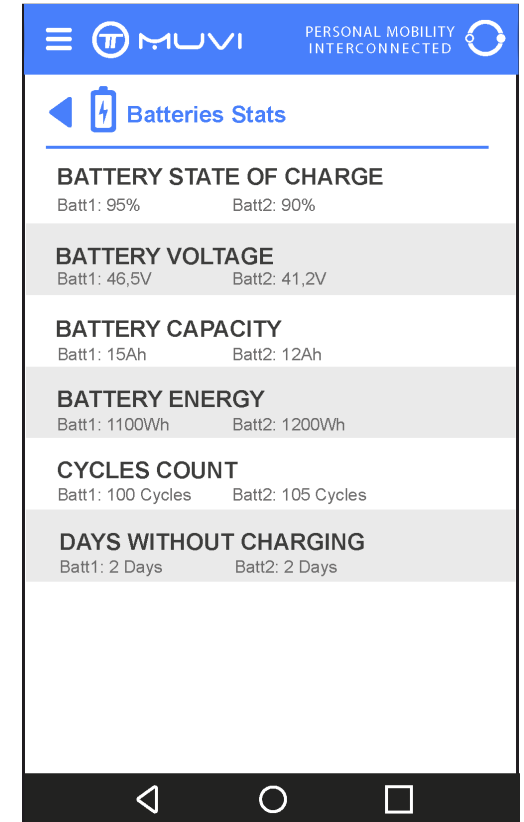

STORAGE COMPARTMENT

The MUVI's storage compartment is designed to hold a helmet*. To open it, remove the key from the ignition and insert it into the lock on the left side of the motorbike. ©

The motorbike batteries are also located inside this compartment. Further below there will be a detailed explanation on how to treat the batteries to avoid deterioration and extend their service life as much as possible.



**NEVER LEAVE THE MOTORBIKE KEYS INSIDE THE STORAGE COMPARTMENT
IF CARRYING ONLY ONE BATTERY ENSURE THAT NOTHING FALLS INTO THE EMPTY BATTERY COMPARTMENT.**

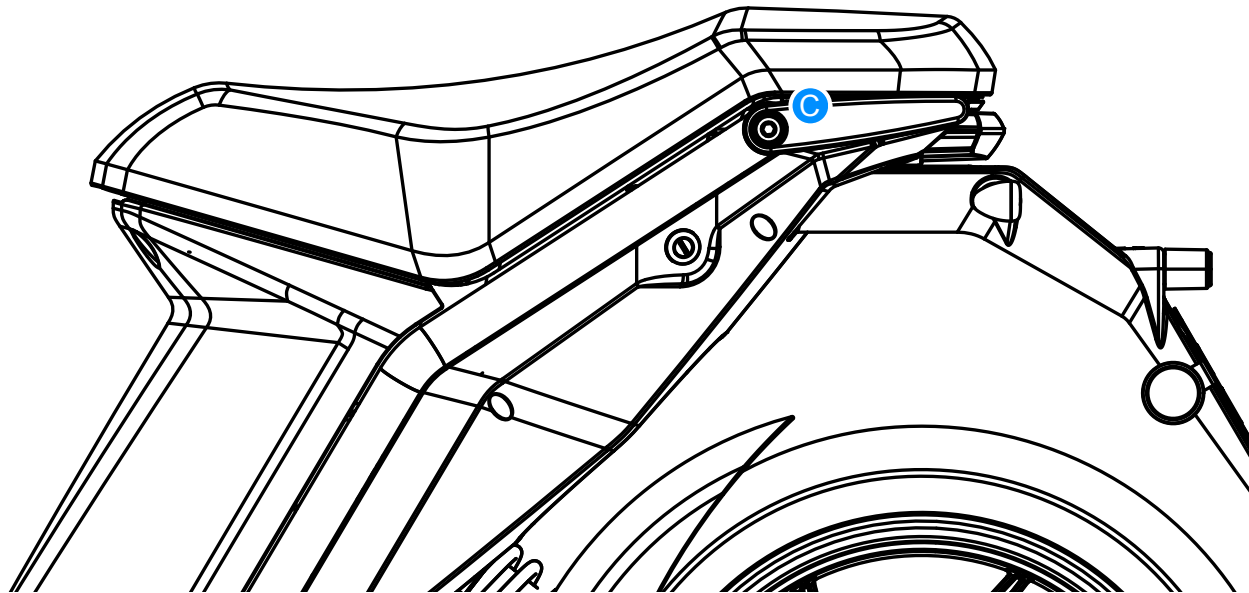

*It must be a jet helmet and there must be only one battery.

USING THE CENTRE STAND

To put the motorbike onto its centre stand when parking, set the ignition switch to OFF. Place your foot on the stand's arm **1** and push downward. To facilitate this move, grasp the handle with your hand and pull upward. **2**

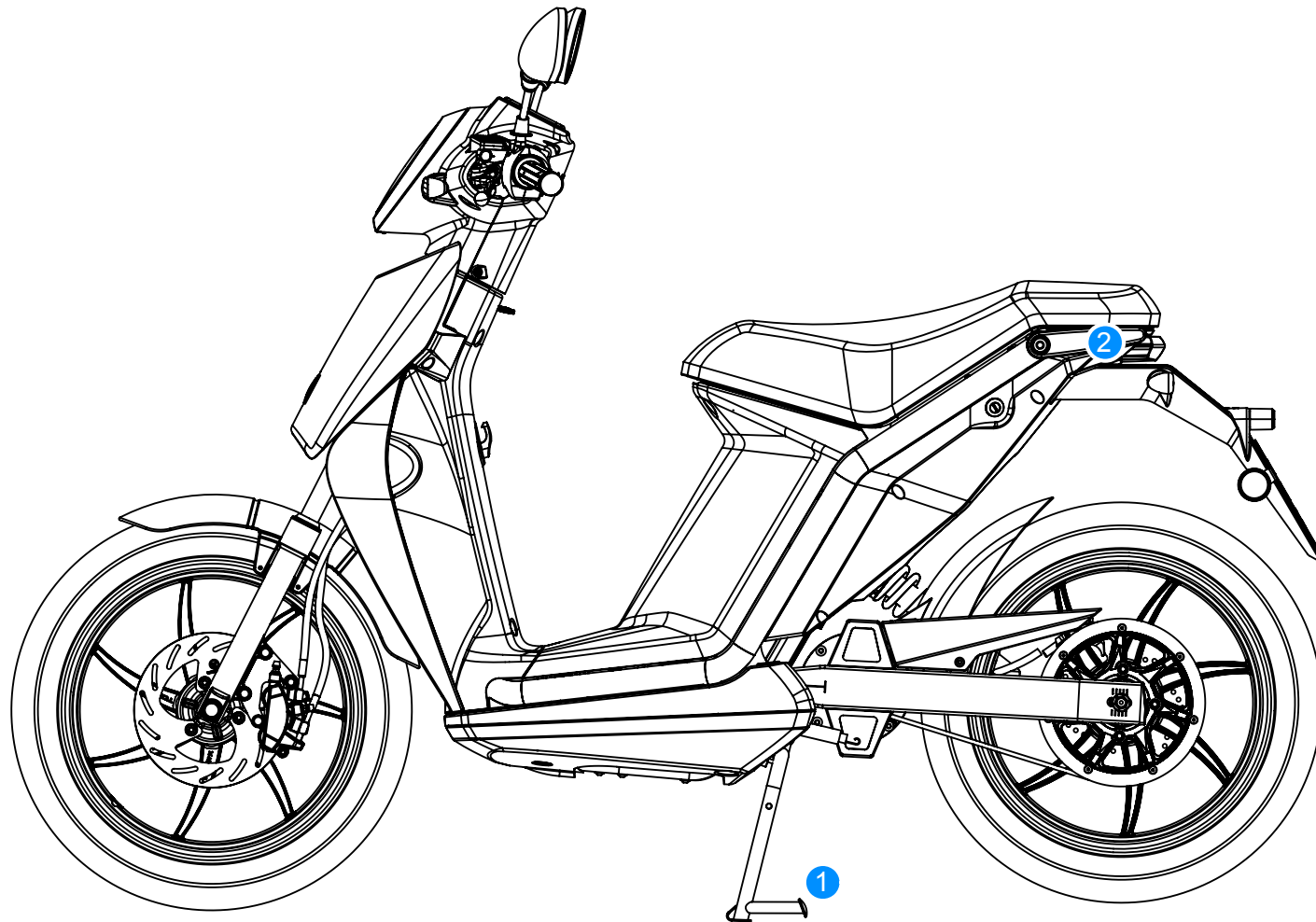

USAGE AND PRECAUTIONS

The speed and maximum range can vary depending on the acquired model.

- L3e-A1: 70km/h
- L1e-B: 45km/h

The range will also vary considerably depending on the driving style and conditions under which the MUVI is subjected to, including route gradient, driving aggressiveness, number of passengers, etc

Hydraulic front and rear disc brakes provide easy braking, requiring very little force on the lever. Using the left brake lever activates the combined braking, distributing it over both wheels.

Avoid sudden braking, doing so can cause loss of stability and control, especially on wet or sandy surfaces.

Before using the motorbike at its full potential, familiarise yourself with it and how it responds. Even the most experienced riders can have accidents under bad weather conditions so it is important to always exercise care when riding.



READ THE “PRE-OPERATION CHECKS”, “CLOTHING” AND “RIDING SAFELY” SECTIONS ABOVE

Use the throttle smoothly in order to ride more efficiently.

What should I do at the end of the product lifetime?

The motorbike should be managed using an authorized waste treatment centre. As the KIDS use recyclable materials, the product has a recycling rate greater than 95%.

Furthermore, the fact that the vehicle was easy to disassemble has been established as a design requirement in order to make easier the recycling of the materials.

TURN-ON SEQUENCE

Turning the key to the ON position turns on the motorbike, however, the motor is not yet operational. The display will show a few turn-on check screens and if there are no errors the speedometer will appear with the word STOP. To get to the ECO/FULL screen and activate the motor you will have to:

1. Ensure the motorcycle is off its centre stand
2. Squeeze one of the two brake levers

Following this sequence stops you from leaving with the stand down and damaging the motorbike. It is also a way of testing the brakes before setting off.

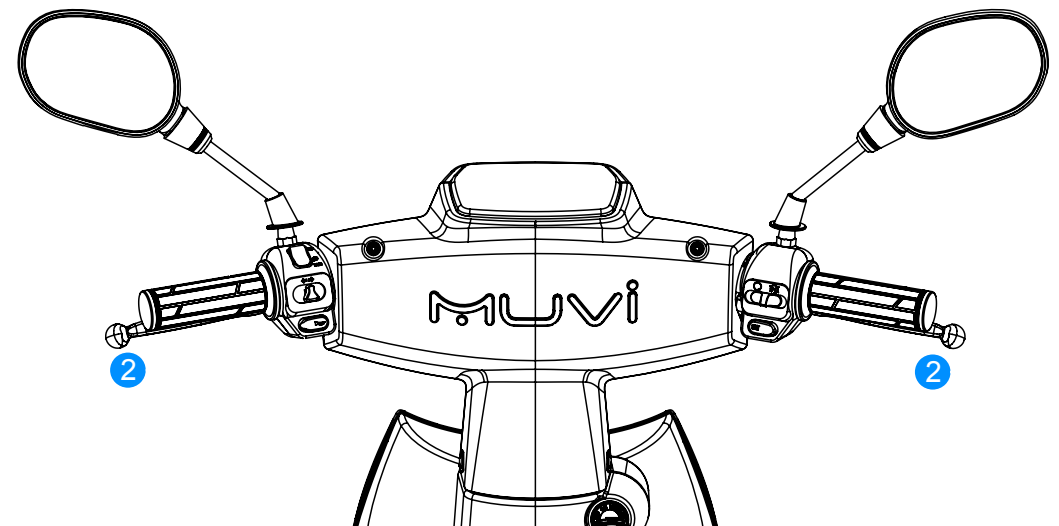
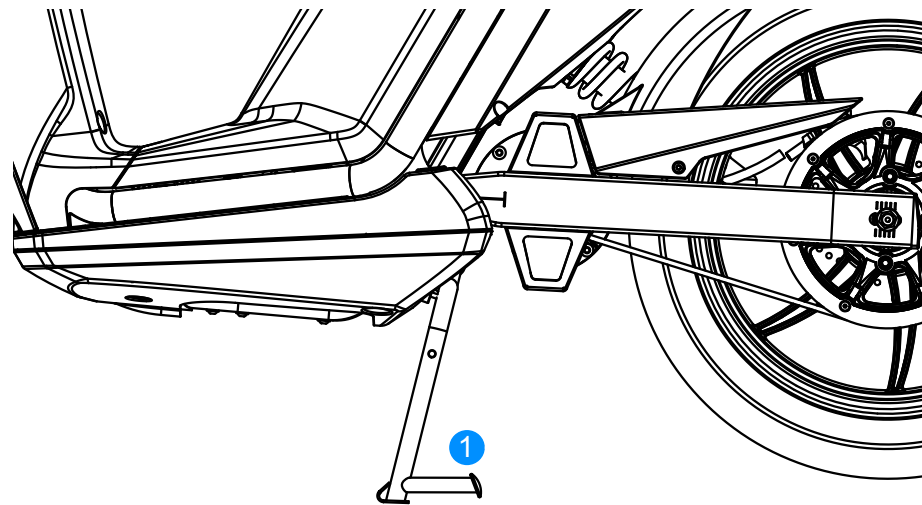

REMOVING THE BATTERIES

One of the aspects that sets this electric vehicle apart from the rest are its portable batteries that are easily removed, allowing them to be charged where desired.

To remove them make sure the motorbike is stopped, open the storage compartment, loosen the Velcro strap and pull off the battery until it comes out, while pulling off the battery with one hand, grasp it with the other hand to steady it. Each battery weighs about 10 kg.



WHEN INSERTING A BATTERY PAY CLOSE ATTENTION THAT ITS COMPARTMENT IS CLEAR OF ANY OBJECTS



NEVER REMOVE THE BATTERIES WHILE THE MOTORCYCLE IS ON.

INSERTING THE BATTERIES

To insert a battery, line it up with the grooves then gently slide it in until it reaches the bottom. Do not let it drop to the bottom as this can damage the connectors. Once they are in position fasten the Velcro strap.



BE CAREFULLY WHEN INSERTING THE BATTERIES. IT MUST FIT PROPERLY, MATCHING THE CHAMFERS OF EACH BATTERY WITH THE BATTERY CONTAINER ONES.

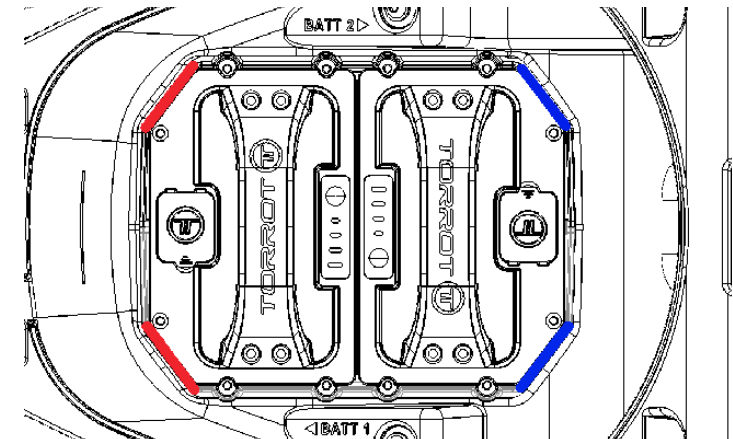
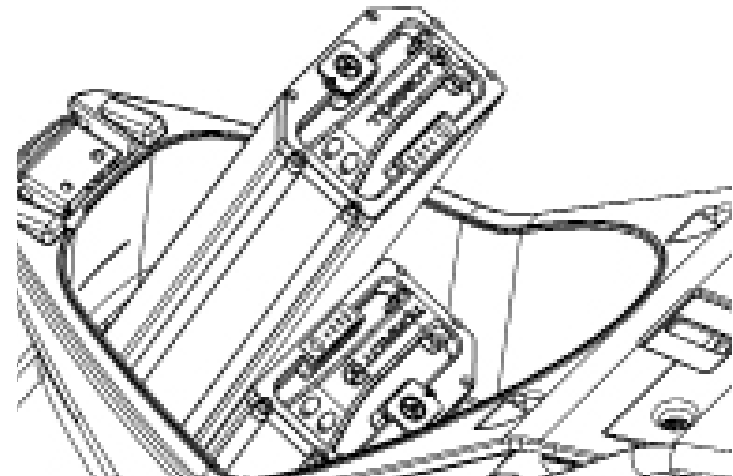

CHARGING THE BATTERIES

As the batteries are removable they can be charged either in or out of the motorbike. If the batteries are in the motorbike their charge level can be seen on the display, if not, the top cover has a charge level indicator. Press the button for a few seconds and the LEDs will light up showing the charge level. The dual charger has two outputs, for charging both batteries simultaneously.

To charge them in the motorbike:

1. Turn the motorbike off
2. Put it onto the centre stand
3. Open the storage compartment and connect both batteries to the charger.
4. Connect the charger to mains power

The batteries are now charging. If you want to see the remaining charge time insert the key into the ignition switch and turn on the motorbike. The display will show the charge status of each battery and the time remaining.

To charge them off the motorbike:

1. Turn the motorbike off
2. Remove the batteries as explained on the previous page
3. Connect them to the charger
4. Connect the charger to mains power



NEVER CONNECT NOR DISCONNECT THE CHARGER FROM THE BATTERY PULLING THE WIRE. APPLY A LOGICAL FORCE TO CONNECT THE CHARGER, IF IT DOESN'T MATCH, REVIEW THE INSERTION POSITION.



BEFORE CHARGING FOR THE FIRST TIME, CHECK THAT THE VOLTAGE SELECTED ON THE REAR IS CORRECT.



ALWAYS CHARGE TO THE LIMIT AFTER EACH USE. DO NOT DISCONNECT THE CHARGER UNTIL LED2 IS GREEN



NEVER CHARGE THE BATTERIES WITH THE CHARGER INSIDE THE STORAGE COMPARTMENT

BATTERY PRECAUTIONS

1. GENERAL

- a. The battery comprises lithium ion cells with a high energy density. It must not be tampered with under any circumstances. Failure to observe this instruction entails electrical and chemical risks, which can result in serious material and personal damage.
- b. The inspection, repair or replacement of the battery, or any of its elements, by personnel not expressly authorised by the manufacturer is strictly prohibited.
- c. The manipulation or repair of any electrical/electronic element of the vehicle (motor, controller, etc.) by personnel not expressly authorised by the manufacturer is strictly prohibited.
- d. Each battery has an electronic device that counts the number of days elapsed starting from the moment the charge level goes below 20% (equivalent to the low-battery warning light in the display). The battery warranty will be null and void once this count reaches 40 days.

2. BATTERY DAMAGE

Any type of vehicle abuse can affect the battery's service life. Observe the following instructions to keep it in good condition and prolong its service life:

- a. Avoid using the vehicle in conditions of extreme heat or cold that go beyond the limits indicated by the manufacturer.
- a. Avoid charging the battery in conditions of extreme heat or cold that go beyond the limits indicated by the manufacturer.
- c. When the vehicle is not being used it should be stored in a dry place, away from sources of heat and/or cold, as well as direct sunlight.
- d. Avoid unnecessary knocks and vibrations to your vehicle. The insulation between the battery and the vehicle's chassis should be

checked regularly to ensure it is in good condition. If it is not, replace it.

e. Self-discharge is a natural characteristic of the battery and should be monitored. In case of prolonged periods of inactivity, it should be regularly charged to its maximum level.

f. Avoid partially charging the battery. For correct daily use, the battery should always be charged to the limit set by the charger.

g. As a general rule, after charging has finished it is advisable to leave the battery connected to the charger for a certain amount of time.

h. Only use chargers that have been supplied directly by the manufacturer or an authorised dealer.

i. During use, avoid abnormally forcing the vehicle.

j. The battery is equipped with integrated protection against electrical hazards, which can engage automatically. If the battery is not working properly, or at all, have it repaired at an authorised technical service centre.

k. Keep the battery clean and in good condition, carefully remove dust, dirt and other foreign elements that can get into the battery compartment during use.

l. If deterioration is detected in the electrical system's conductors, turn off the vehicle and take it to an authorised Torrot technical service centre.

m. Water, mud or similar must not come into direct contact with the vehicle's electrical system. If water has accidentally entered any of the vehicle's electrical elements, turn it off and wait for it to dry naturally before using it again.

MAINTENANCE

As with all electric vehicles, the MUVI requires less maintenance than equivalent combustion vehicles. Following, we will address a few maintenance issues that you should carry out.



IF YOUR MOTORBIKE DOES NOT WORK, DO NOT ATTEMPT TO FIX IT YOURSELF AS YOU COULD RISK INJURY OR WORSEN THE PROBLEM. TAKE IT TO AN AUTHORISED WORKSHOP AND WE WILL HAVE IT READY FOR YOU AS SOON AS POSSIBLE.



DO NOT FORGET TO REMOVE THE BATTERIES BEFORE CARRYING OUT MAINTENANCE.

BELT TENSION

The belt tension should be 80-85 Hz. This can be measured with a belt tension gauge. If you lack the required know-how, contact your trusted workshop, or the closest Torrot-authorized one, and have them adjust the belt.

TYRE PRESSURE

Riding with a tyre pressure different to that recommended can cause inappropriate tyre wear, less surface grip, and consequently, less control over the motorbike which can lead to an accident. Apart from avoiding all this, keeping the tyres at the correct pressure will also prolong their service life. Change the tyres when the tread depth reaches that established by traffic regulations. After changing the tyres make sure both have the same, and correct, pressure.

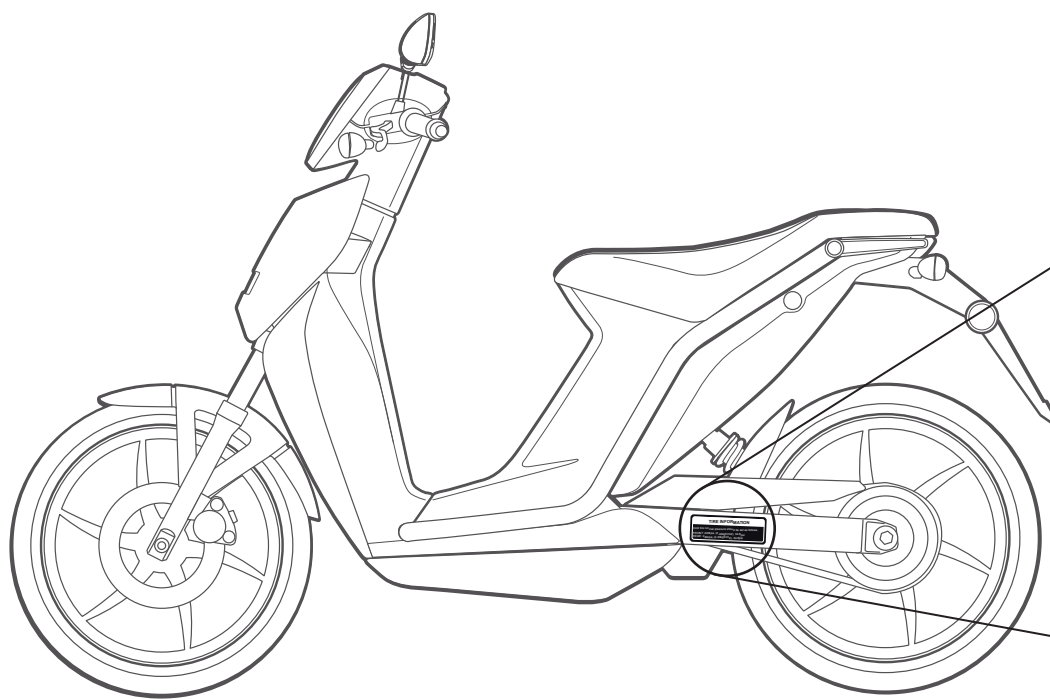

TIRE INFORMATION

Cold tire normal pressure should be set as follows:

FRONT: 240kpa, (2.40kgf/cm²), 34.8psi

REAR: 240kpa, (2.40kgf/cm²), 34.8psi

BRAKE FLUID

Regularly check the brake fluid level where indicated in the picture. Too low a level can cause deficient braking and lead to an accident. The brake fluid reservoir **D** has a circular transparent window. The minimum level is situated slightly above the bottom of the window, and the maximum, at the top of the window.

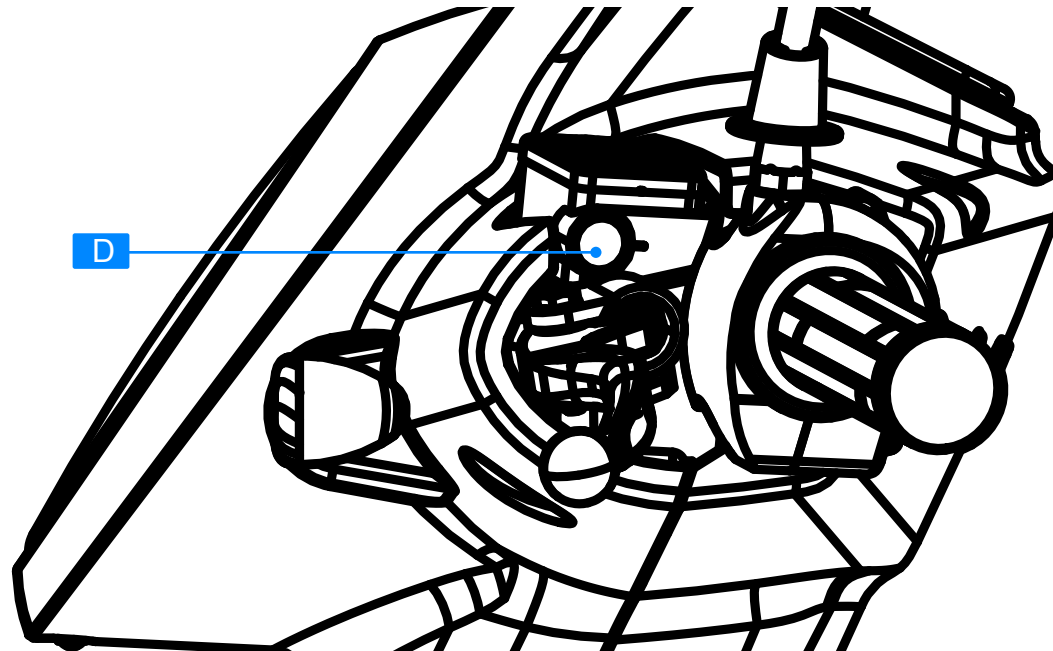

BRAKE CALLIPERS

Check the brake pads regularly to see if the thickness is less than 1mm. If this is the case then have them replaced with new ones.

ACCESSING THE HEADLIGHT

If you notice the headlight is emitting less light, or none at all, then it needs replacing. To access the light bulb, take off the rear handlebar cover by removing the screws **T** shown in the picture. Once the screws are out, remove the plastic cover by detaching the tabs **P** shown in the picture. Be careful when removing the plastic cover as the ECU is screwed to it. Separate the plastic cover from the motorbike by uncoupling the ECU connector.

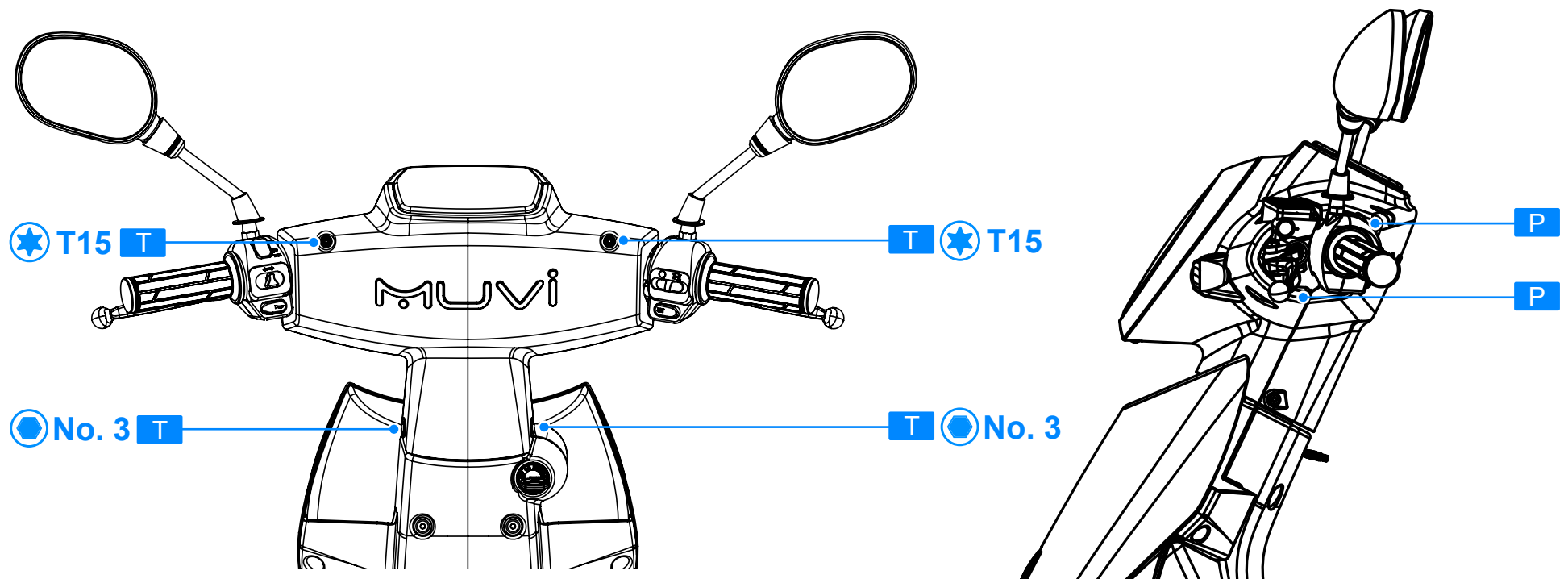

CHANGING THE LIGHT BULB

You now have rear access to the headlight. Start by removing the black rubber protector on the rear of the headlight. Next, uncouple the headlight connector. You will see the bulb retention clip, one of its sides terminates in two ends. **E** Press one of these ends inward then sideward to remove from its position. Do the same with the other end. The light bulb is now loose and can be replaced with a new one.

Reverse this procedure to reassemble the headlight.

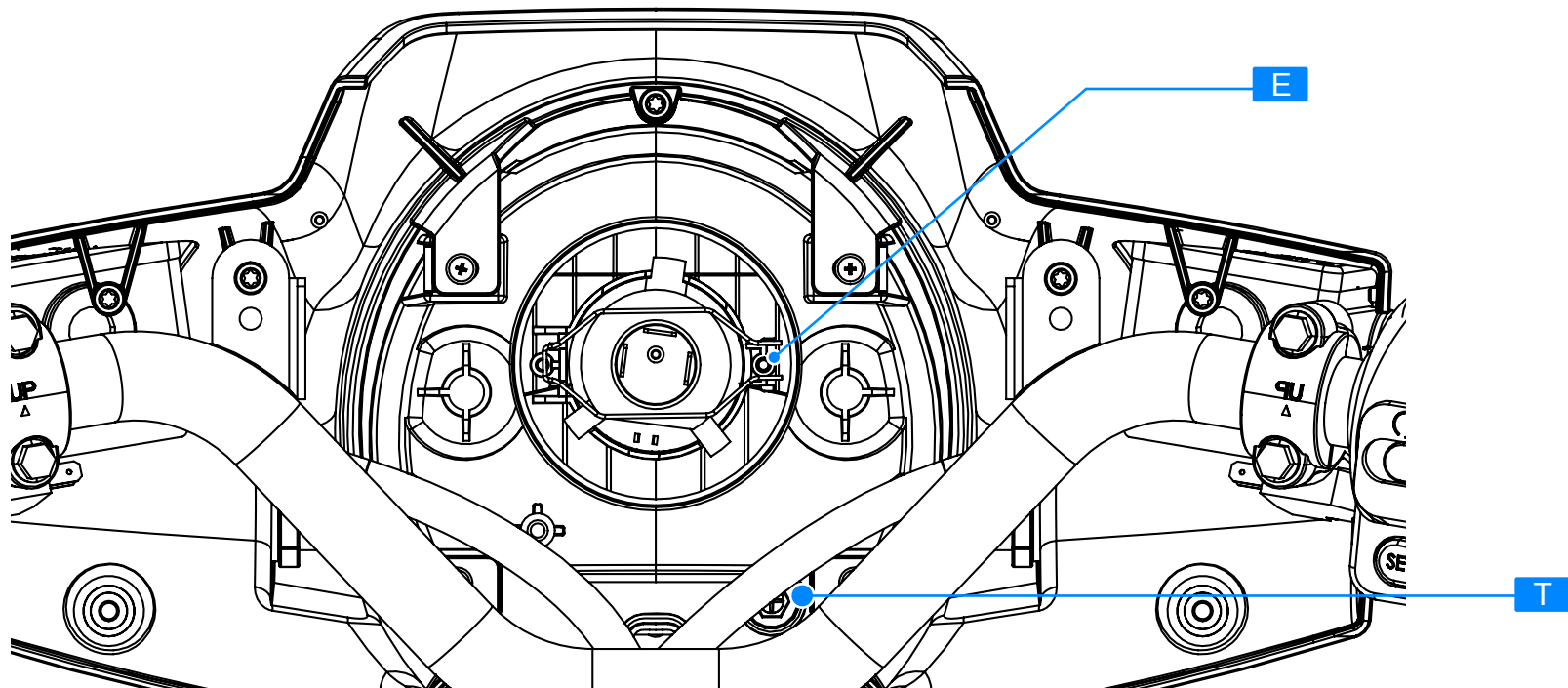

ADJUSTING THE HEADLIGHT

The headlight beam can go askew due to motorcycle use or a bulb change, making adjustment necessary.

A headlight aim check must be performed on level ground with the tyres inflated and a person sitting on the motorbike.

With the motorbike upright and the wheel touching a wall, mark the light bulb's height with respect to the ground.

Move back 10 metres perpendicularly from the wall and turn on the headlight.

The highest part of the beam should be 10% under the previous position.

For example: If when touching the wall the light bulb's height is 100cm, when you move back 10 metres, the highest part of the beam should be at 90cm (100×0.9).

To adjust the beam height, loosen or tighten the screw  shown on the previous page.

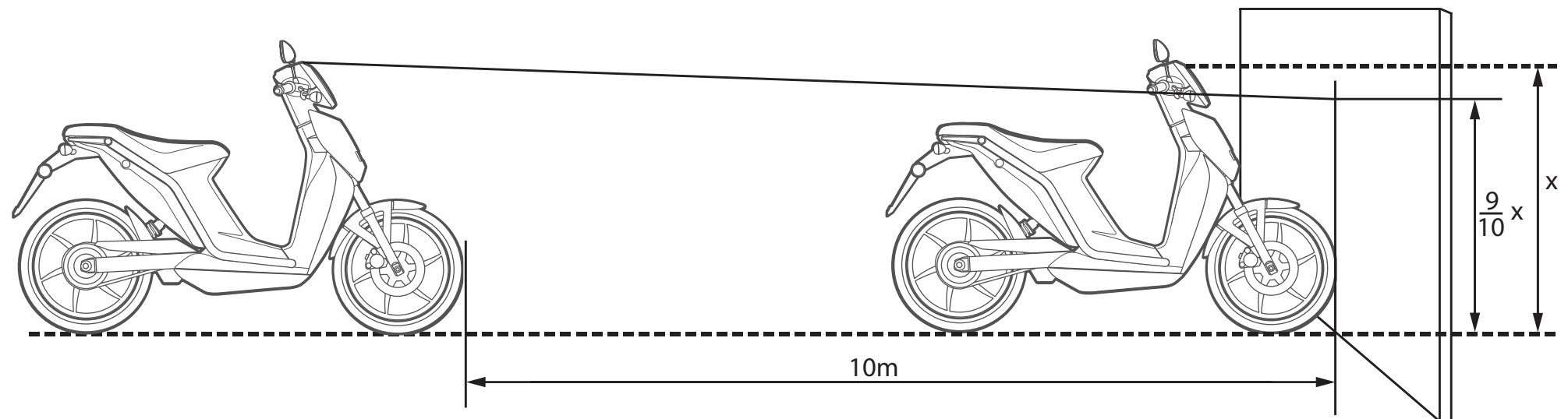

CLEANING

To prolong the life of the fairings and other components it is important to keep the motorcycle clean. Dust and grime that accumulates on the motorbike's exterior can end up penetrating into its interior, affecting electronic components.

Clean the motorbike with a damp cloth, soapy water or a spray especially for cleaning plastics.

Do not clean with a pressure washer or a hose as water could get into the electronic components.

If you are not going to use the motorbike for a long time remember to follow the instructions regarding the batteries. When storing the motorbike, clean and let it dry, put it onto the stand and cover with a tarpaulin. Regularly check that everything works properly and cover it again.

STICKER LOCATIONS

Each of the MUVI's components has a sticker that indicates its model and serial number. Let's take a look at where these stickers are.

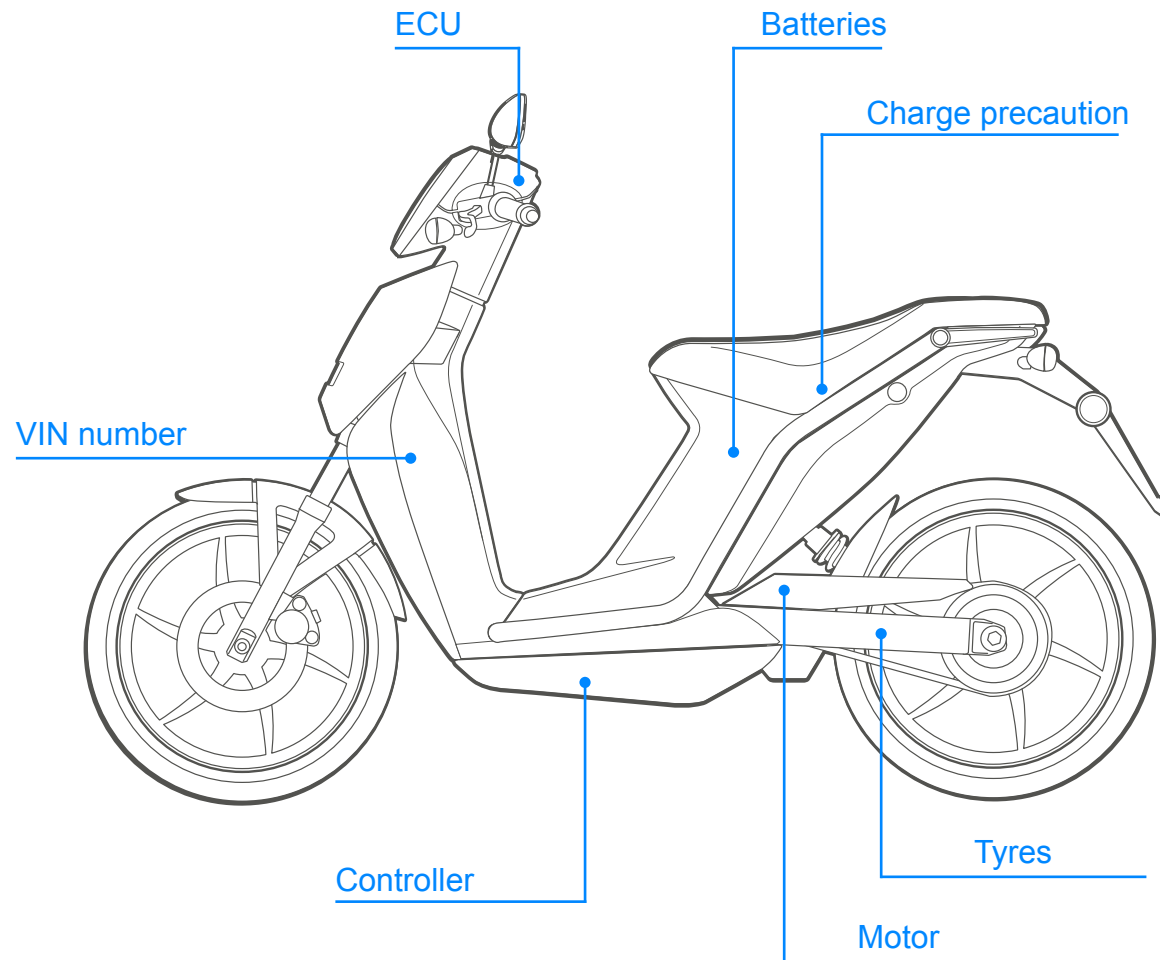

VIN NUMBER

The VIN number, or serial number, is engraved on the metal tube that leads to the chassis' steering head. Just beside this is the Manufacturer's Data Plate, which is indelible. It indicates the manufacturer's name as well as the VIN number.

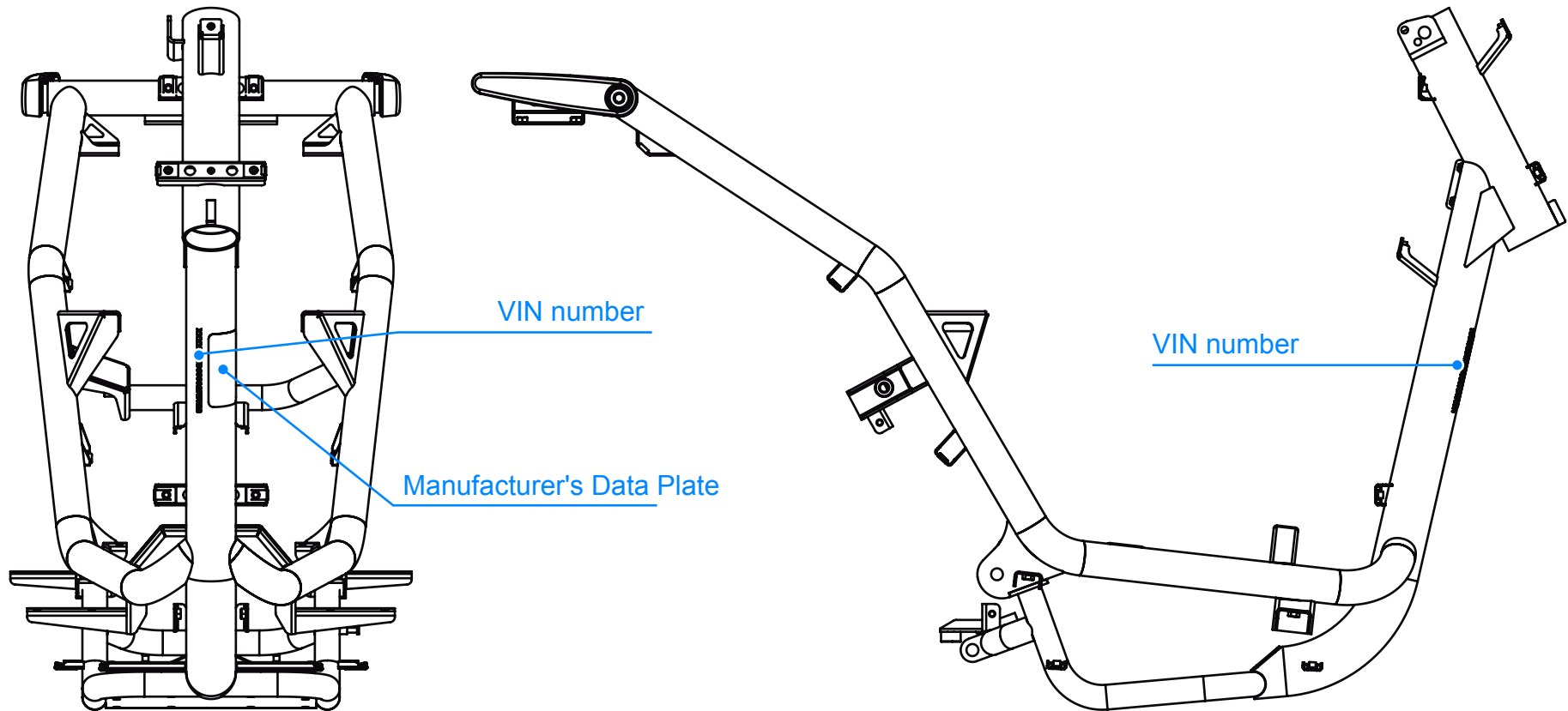

WARRANTY TERMS AND CONDITIONS

Torrot Electric Europa S.A. guarantees to the owner that only the original components of each new Torrot Electric vehicle show no defects in materials, nor in labour during the following specified periods:

Two (2)-year [three (3)-years for Spain & Portugal] warranty on:

- Any original component or part of a Torrot Electric vehicle (KIDS and MUVI).
- MUVI batteries are warrantied for two years [three years for Spain & Portugal] or 40,000 km within this period, as long as the use and maintenance conditions set out in the manual are observed.
- The batteries in our KIDS vehicles, as long as the use and maintenance conditions set out in the manual are observed.

This warranty applies only to Torrot Electric vehicles bought new from an authorized Torrot Electric Europa S.A. dealer or directly from the manufacturer via online and which were assembled by that dealer or the manufacturer at the time of purchase. This warranty does not cover unauthorized parts or parts fitted by companies not explicitly authorized by Torrot Electric Europa S.A.

This warranty is only applicable to Torrot Electric electric vehicles and bicycles purchased new from an authorised Torrot Electric Europa S.L. dealer or directly from the manufacturer via its website and which have been assembled by the said dealer or the manufacturer at the time of purchase. This warranty does not cover

unauthorised parts or their installation by companies not expressly authorised by Torrot Electric Europa S.L.

LIMITED REPAIR

Unless decided otherwise, the only repair under the abovementioned warranty, or any implicit warranty, is limited to replacing defective parts for others of equal or greater value in the original vehicle, which is entirely at Torrot Electric's discretion. This warranty applies from the date of purchase and is applicable only to the original owner and is non-transferable, except for the MUVI electric scooter (see warranty transfer section).

In no circumstances shall Torrot Electric be liable for direct, incidental or consequential damages, including, without limitation, damages for personal injuries, property damages or financial losses, be it on the basis of contract, warranty, negligence, product liability or any other theory.

EXCLUSIONS

The foregoing warranty, or any implicit warranty granted by Torrot Electric Europa S.A., does not cover:

- Normal wear and tear on parts such as tires, chains, pinions, rear sprockets, brakes and hoses in situations where there are no assembly or material defects.
- Vehicles that are maintained or repaired by persons who are not authorized by the manufacturer or who are unconnected to Torrot Electric.

- Modifications from the condition in which the vehicle was originally supplied.
- The use of Torrot Electric vehicles for abnormal, competition, and/or commercial activities or for purposes other than those for which they were designed.
- Damage caused by not following the owner manual instructions.
- Damage to the paint finish derived from participating in competitions and/or training for such activities or events or as the result of exposure or the use of Torrot Electric vehicles in extreme conditions or weather.
- Damage caused by external agents such as chemical products, salt, rust, discoloration or natural deterioration.
- Logistical and labour costs incurred in making the replacement or change.

Except where provided for in this warranty and subject to all the additional warranties, Torrot Electric and its employees and agents shall not be held liable for losses or damages, of whatever kind (including incidental and consequential losses or damages caused by negligence or omission) derived from or related to any Torrot Electric vehicle.

Torrot Electric Europa S.A. does offer any other warranty, whether explicit or implicit. All implicit warranties, including the warranties of marketability and suitability for a particular purpose, are limited in duration to that of the explicit warranties set out above. Any claim under this warranty must be filed through an authorized Torrot Electric dealer or directly online or by postal mail to Torrot Electric Europe S.A. The original purchase invoice bearing the date of purchase and VIN number is required before a warranty claim can be processed.

Warranty claims filed outside the country of purchase may be subject to additional fees and restrictions, and unless otherwise stated shall be covered solely and directly by the importer in the country or region outside Spain.

The term and details of the warranty may vary depending on the type of vehicle, battery and/or the country. This warranty grants specific legal rights; however, you may also have other rights that may vary by place. This warranty does not affect the rights established by the law.

ANNEX/ES

ONLINE WARRANTY REGISTRATION

To validate and activate the warranty, the vehicle must be registered by the dealer or importer.

WARRANTY TRANSFER (ONLY MUVI)

The transfer of the warranty shall apply to the new user when they show they have concluded the change of ownership of the vehicle according to laws in force in each country, binds the manufacturer in Spain and the importer in all other countries.

USER RESPONSIBILITIES

Torrot Electric Europa S.A. asks the user to meet certain requirements of good maintenance and use of its vehicles to be able properly to support a warranty claim. During the warranty term, your vehicle must only be serviced by Torrot Electric Europa, Torrot Electric importers or authorized official dealers. You are responsible for keeping your vehicle in good condition and to not subject it to greater stresses than those of ordinary use. During the validity period of the warranty, you must pass all the mandatory periodic technical inspections as indicated in the owner's manual in each Torrot Electric vehicle model. Otherwise, the warranty would be automatically invalidated.

The owner of the Torrot Electric vehicle accepts and understands that, in purchasing a Torrot Electric vehicle, the warranty does not cover repairs for damage caused by from misuse, abuse, accident or neglect, nor does it cover units with the following characteristics:

- Specifications altered from those in its original configuration, as specified in the technical datasheet, manual or on the website www.torrot.com
- Vehicles used in competition, where that refers to time trials, competing with another vehicle or any other application involving abnormal stress.
- Vehicles lacking proper maintenance, cleaning or where the relevant mandatory periodic services details in the owner's manual according to each model have not been carried out.
- Vehicles where the distance counter (odometer), or any other electronic component (controller, electronics...) has been altered.
- Vehicles that are rented out.
- Observe the maximum load weight authorized for each vehicle, as stated in the owner's manual and in the technical characteristics in any offline and online Torrot Electric Europa S.A. product catalogue.
- Parts that wear out due to natural use, such as: batteries, brake calipers and pads, secondary transmissions, tires, upholstery, electric components, suspension elements, etc.
- Electrical/electronic circuit altered by modifying its original performance that are not the original or not explicitly authorized by Torrot Electric Europe S.A.
- Batteries in which an unauthorized or unofficial charger has been used, and batteries in which there has been overcharging or uncontrolled charging.

This warranty does not cover the cost of the mandatory periodic maintenance services, nor that of the routine services specified for each model in the owner's and maintenance manual.

For any problem that may arise in your vehicle, please write to info@torrot.com; state the VIN number, the problem detected, and your name and a contact telephone number. Our technicians will quickly get in touch with you, and after a telephone pre-assessment, they will determine the procedure to follow as soon as possible.

TORROT ELECTRIC AFTER SALES SERVICE

Consult the map of authorised dealers on our website.



THE LATEST INFORMATION AT WWW.TORROT.COM/ES/TIENDAS
FIND YOUR CLOSEST TORROT ELECTRIC DEALER FOR CITYSURFER OR KIDS. VISIT
THEM FOR THE BEST AFTER SALES SERVICE ;-)

OWNER'S MANUAL PRODUCED BY **TORROT ELECTRIC EUROPA S.L.**



© V1 08/2016 TEESL / TORROT ELECTRIC EUROPA S.L. ALL RIGHTS RESERVED. TOTAL OR PARTIAL REPRODUCTION OF THIS MANUAL WITHOUT PREVIOUS WRITTEN PERMISSION FROM THE COPYRIGHT OWNER IS FORBIDDEN.

IMAGES ARE NOT CONTRACTUAL. DUE TO THE CONSTANT IMPROVEMENT POLICY OF TORROT ELECTRIC EUROPA S.L., SPECIFICATIONS AND EQUIPMENT MAY VARY WITHOUT PRIOR NOTICE.

Serious fun.



 **TORROT**
(0034) 972 850 797

 info@torrot.com

 [torrotelectric](https://www.facebook.com/torrotelectric)

 [@torrotelectric](https://twitter.com/torrotelectric)

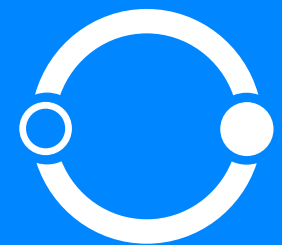

PERSONAL MOBILITY
INTERCONNECTED